

### Area ionizer ER-X series

CME-ERX No.0024-33V

Thank you for purchasing Panasonic products.  
Read this Instruction Manual carefully and thoroughly for the correct and optimum use of this product.  
Kindly keep this manual in a convenient place for quick reference.

### WARNING

- Never use this product as device for personnel protection.
- In case of using devices for personnel protection, use products which meet laws or standards, such as OSHA, ANSI or IEC etc., for personnel protection applicable in each region or country.

## 1 FOR SAFETY USE

### WARNING

- This product produces high voltages.
- Do not use this product in places where there may be a danger of flammable or combustible items being present.
- To prevent electric shock and to conduct proper discharge, be sure to ground a frame ground (F.G.) terminal of a controller.
- Do not place hands near the discharge needle. Doing so may cause electric shock.
- Since the tip of the discharge needle is sharp, take sufficient care in handling the discharge needle, or injuries may result.
- The high-voltage cable between the head and the high-voltage unit must be fixed and the minimum bend radius is R30 mm or more.
- In case of using at the bend radius R30 mm or less and using at moving part may cause fire and break down, etc. of the high-voltage cable.
- Clean the discharge needle regularly (about once a week). Otherwise, optimum charge removal performance may not be achieved, and accidents or operating problems may occur.
- If this product is used in a confined space, ozone emitted from this product may be detrimental. Be sure to provide ventilation.
- Do not direct ionized air toward the face. Ozone may cause irritation to places such as the nose and throat.

### CAUTION

- This product has been developed / produced for industrial use only.
- Do not use this product for purposes other than electric charge removal.
- Do not use this product in environments which are outside the specification range, otherwise operating problems or damage may occur. In addition, the operating life of the product may become significantly reduced.
- This product is a precision device. Do not apply a shock to it by dropping, for example. Accidents or operating problems may occur.
- Never disassemble, repair or modify this product. Accidents or operating problems may occur.
- Do not throw this product in fire. It may explode or toxic fumes may be generated.
- Do not run the wires together with high-voltage lines or power lines or put them in the same raceway. This can cause malfunction due to induction.
- When connecting/removing the head or performing wiring or inspection work, be sure to turn off the power first. Not doing so may result in accidents, electric shock or operating problems.
- After connecting the cables, check that the connections are correct before turning on the power. If the cables are connected incorrectly, operating problems or accidents may occur.
- Verify that the supply voltage variation is within the rating.
- In case using switching regulator, be sure to connect F.G. terminal.
- Do not use any cables which have any damage (such as splitting or cracking), otherwise operating problems or accidents may occur.
- Avoid using the product in places where there are high levels of steam or dust in the air or where it might be directly exposed to water, oil or welding spatter.
- Do not touch the discharge needle with hard objects such as tools. If the discharge needle becomes broken, it will not provide sufficient charge removal performance, and moreover operating problems or accidents may occur.
- During installation, fasten the product securely. If it is not securely fastened or it is subjected to continuous vibration or shock, accidents or operating problems may result.
- Use cables that are 0.15mm<sup>2</sup> or more and 30m or less in total length for wiring. Also, keep the wiring as short as possible in order to prevent noise.
- When disposing of this product, treat it appropriately as industrial waste.
- After starting discharge, it takes approximately 30 minutes for charge removal performance to stabilize. Therefore, wait 30 minutes before adjusting ion balance.

## 2 PART DESCRIPTION

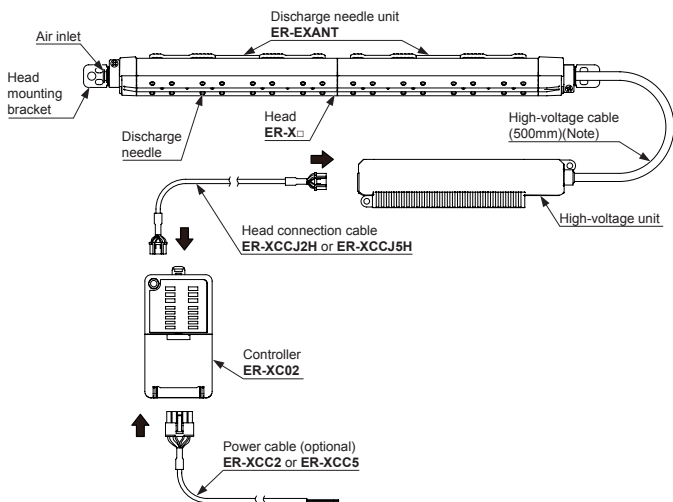

Note: The minimum bend radius of the high-voltage cable is R30 mm.

### < Controller >

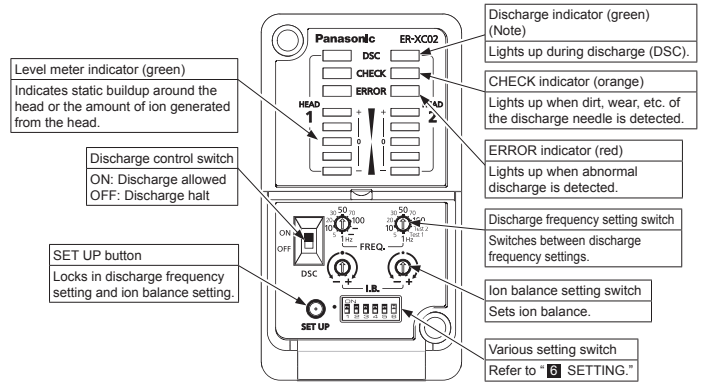

Note: An abbreviation of DISCHARGE.

## 3 INSTALLATION

### < Head installation >

- Using 2 M4 screws or 1 M6 screw, mount the head onto the equipment housing. In case using this product in where there is vibration, use spring washers etc. as a countermeasure.
- Loosen the angle adjustment screw, adjust the head angle, and then fasten the head with the tightening torque of 0.5 N·m or less.
- After mounting the head, set the controller according to the procedures in "6 SETTING" in order to appropriately remove static electricity.

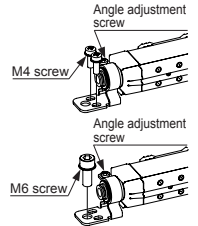

- Notes
- Be sure to ground the equipment housing onto which the head is mounted.
  - The distance between the head and the charge removing object should be 30 mm or more. If the static buildup of the charge removing object is 30 kV or more, set the distance to 50 mm or more.
  - If there is metal near the head or between the head and the charge removing object, ion is absorbed, hindering appropriate static removal. Install the head based on the above.
  - In case using the side mounting, the discharge frequency should be 10Hz or more.

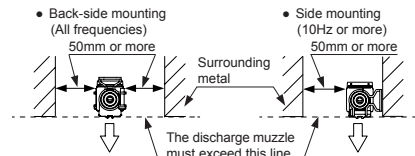

- When installing two or more heads in face to face or parallel using different frequency, keep the distance between the heads 400mm or more.

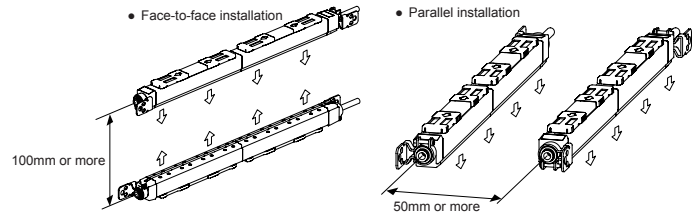

### <High-voltage unit installation >

- Using 2 M4 screws, fasten the unit with tightening torque of 1.2 N·m or less.

- Notes
- Do not place any objects on top of the high-voltage unit.
  - When using multiple heads, keep the distance of at least 10 mm between the high-voltage units.

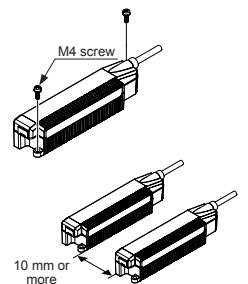

### < Controller installation >

- Mount the controller on a 35 mm wide DIN rail or using M4 screws. For mounting dimensions, refer to "14 DIMENSIONS"

#### When mounting on a DIN rail

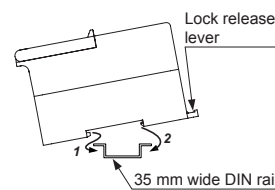

- Pull the lock release lever to remove this product from the DIN rail.

#### When mounting using M4 screws

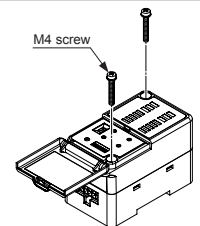

- The tightening torque should be 1.2 N·m or less.

## 4 WIRING

- Power connector Pin arrangement



(Front view)

Housing: 5669-10A  
[Manufactured by Molex Inc.]

Terminal No.	Terminal name	Color code
1	0V	Blue
2	COM(-)	—
3	Discharge control input	Pink
4	COM(OUT)	Violet
5	F.G. terminal	Green/Yellow
6	24V	Brown
7	COM(+)	—
8	—	White
9	Alarm output	Orange
10	Error output	Black

Note: Wire colors are colors of power supply cable of option.

- When connecting the output to negative common

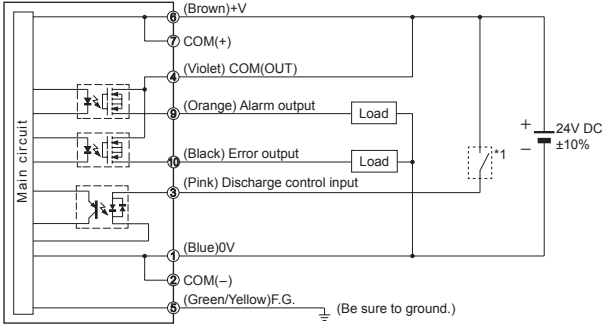

- When connecting the output to positive common

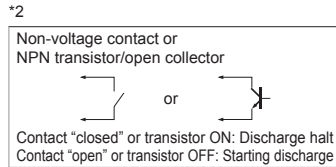
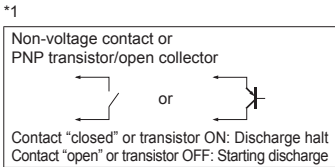
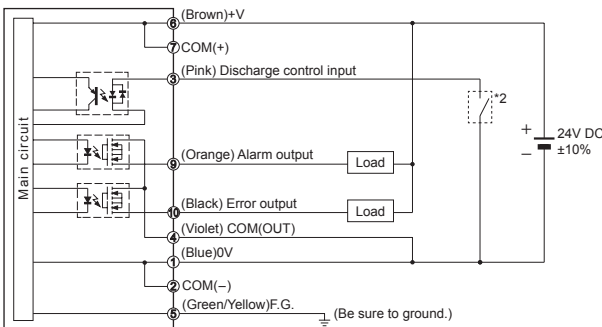

- Notes
- In order to prevent electric shock and perform proper discharge, be sure to ground the F.G. terminal.
  - To stop discharge, turn ON the discharge control input for 20 ms or longer. To start discharge, turn OFF (open) the discharge control input. Discharge will start in 20 ms.

## 5 PIPING

- Air supplied to this product will reduce contamination of the discharge needle and improve the charge removal speed.
- The outer diameter of the air tube to fit to the air inlet portion of this product should be  $\phi 6$  mm.
- Make sure that clean air (air containing no water, no oil and no dust) should be supplied.
- Since the pressure will drop when the air piping from the main pressure supply is extended or pneumatic components (e.g., needle valve, speed controller, mini filter) are added, keep an eye on the pressure supply to the ionizer making sure it is not in short supply. For the pneumatic components, select those that can accommodate the air supply flow rate.

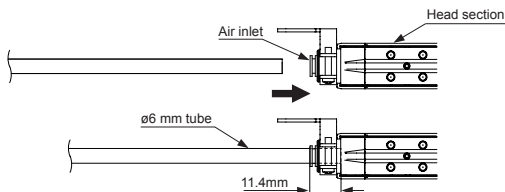

Note: After inserting the tube into the joint of this product, always make sure that the tube is all the way in and securely inserted. Insufficient tube insertion will cause air leakage.

## 6 SETTING

- The amount of ion generation is set to enable appropriate charge removal.
- After mounting the head, follow the procedures below to configure the setting.
- When air is used, configure the setting while supplying air.
- Start the setting after 30 minutes of the discharge starting.

### How to set the amount of ion generation

Discharge control switch



- Turn the discharge control switch ON and the discharge control input "open" to start discharge. Make sure that the discharge indicator (green) lights up.
- Depending on the installation distance, set the frequency using the discharge frequency setting switch.
  - Guideline when air is not supplied

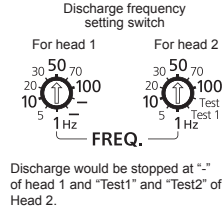

Installation distance	Discharge frequency setting switch	Frequency
30 to 50mm	100	100Hz
	70	70Hz
50 to 200mm	50	50Hz
	30	30Hz
200 to 500mm	20	20Hz
	10	10Hz
500 to 1,000mm	5	5Hz
	1	1Hz

- When air is supplied, Set the frequency higher than when air is not supplied. Try 50 Hz (factory default setting) first to see if it removes static electricity. Since using air, discharge distance from the object can be longer.
- If the amount of static build up on the charge removing object is large, Set the frequency lower or make the installation distance shorter.
- In case the voltage resistance of the object is low, Set the frequency higher or make the installation distance longer.

- After mounting the head, adjust ion balance using the ion balance setting switch.

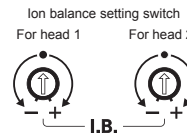

Turn to "-" to shift ion balance to the "-" side.  
Turn to "+" to shift ion balance to the "+" side.

Note: Generally, ion reaching the charge removing object is affected by installation environment (nearby metals, temperature, humidity, etc.). Although this product has been adjusted for ion balance at the factory, the preadjusted ion balance may differ, depending on the customer's installation environment. For more appropriate static removal, please adjust ion balance according to your installation environment.

- Press the SET UP button to lock in the setting. After the setting is completed, level meter indicators change from blinking to lighting up.

SET UP button



- Notes
- Conduct the maintenance before setting.
  - Before the setting up, be sure that the check indicator is turned OFF. In case the check indicator lights up or blinks, the set up is not started. For detail, refer to "TROUBLE SHOOTING."
  - This product works at factory setting before finishing setup (level meter indicator blinks.) And ion balance control function works at OFF in despite of setting of ion balance control switch. After press down the set up button and finishing he setting (level meter indicator lights up), starts ion balance control and detecting function of ion generation depression amount based on your environment.
  - It takes 30 seconds to 1 minute to complete a setup procedure. Do not change the ambient environment at the time. In case ambient environment is changed, the set up is not conducted and level meter indicator may blink.
  - In case the discharge frequency setting switch or the ion balance control switch is changed or installed environment is changed, conduct the setup again.
  - The set up is conducted to two heads. Do not wire head that you do not use.
  - Setting the ion balance setting switch shown right, level meter indicators blink. And pushing down the SET UP button for 3 seconds in this setting, the setting will be the factory setting.

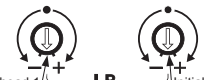

Initializing mode for head 1

Initializing mode for head 2

### Various setting switch

Various setting switch	Name	Function
	Check level changeover switch	Switches between ion generation levels to output an alarm. ON: Lights up the CHECK indicator and outputs an alarm, when ion generation is reduced to a level that affects static removal. OFF: Set this if you wish to be alerted soon after ion generation is reduced.
	Ion balance control switch	Switches between automatic ion balance control function settings. ON: Enables automatic ion balance control function. Senses the amount of ion generation and automatically controls it to match the setting of the ion balance setting switch. OFF: Disables automatic ion balance control function. Ion continues to generate at the discharge ratio setting of the ion balance setting switch.
	Indicator change-over switch	Switches between indications of the level meter indicator (green). ON: Indicates the static buildup state of immediate head. It shifts to the "+" or "-" side depending on the amount of buildup. (Example) When the charge removing object is positively charged. OFF: Indicates the amount of ion the head generates. Plus ion generated is indicated on the "+" side and minus ion on the "-" side. (Example) When a sufficient amount of plus and minus ions are generated.
	2 heads control switch	Sets ion generation timing for two heads. If the two heads have different discharge frequency, this setting will be invalid, and ion will be generated at the frequency timing of each head. ON: When head 1 is generating plus ion, head 2 also generates plus ion. (synchronous mode) OFF: When head 1 is generating plus ion, head 2 generates minus ion. (inversion mode)
	—	Not used.

- Notes
- All factory default settings are ON.
  - Checking function (detecting function of ion generation depression) is based on amount of ion generation which was set in the set up.

## 7 OUTPUT FUNCTIONS

### < Alarm output >

- Normally OFF
- The alarm output switches from OFF to ON at the occurrence of a reduction in ion generation, installation error, excessive discharge to nearby metals and abnormal setup data, etc.
- During an alarm, discharge (charge removal) continues.

### < Error output >

- Normally ON (Turning ON after 3 seconds of power supplying)
- The error output switches from ON to OFF at the occurrence of abnormal discharge, output short circuit, etc.
- During an error, discharge (charge removal) stops.
- The error will not be cleared until its cause is eliminated and the power or discharge control switch is turned on again.

Note: Refer to **8 TROUBLESHOOTING** for actions to be taken at the occurrence of an alarm and error.

### < Forced output functions >

- With this product, alarm output and error output can be forcedly-outputted by setting the discharge frequency setting switch for head 2 to Test1 or Test2, respectively.

Discharge frequency setting switch for head 2	Output	Description
	Alarm output	Set the discharge frequency setting switch for head 2 to Test1. Alarm output will be forced to switch from OFF to ON, generating an output.
	Error output	Set the discharge frequency setting switch for head 2 to Test2. Error output will be forced to switch from ON to OFF, generating an output.

Note: During the enforced output, discharging of head 2 will be stopped.

## 8 TROUBLE SHOOTING

- Always be sure to turn off the power before checking the discharge part.

Output	Indicator	Cause	Remedy
-	Discharge indicator (Green) flashes	Discharge stopped.	Check whether the discharge control switch is ON, the discharge control input is not shorted or discharge frequency setting switch is not at "-", "Test1" or "Test2".
Alarm ON	CHECK indicator (orange) lights up	The discharge needle unit is not in place.	Check whether all the discharge needle unit is properly fitted to the main body.
		Discharge needle is dirty	Clean the discharge needle and its surroundings. Refer to <b>9 MAINTENANCE</b> for details.
		Discharge needle is worn	If the CHECK indicator (orange) does not turn off even after cleaning, replace the discharge needle unit, as it may be worn.
Alarm ON	CHECK indicator (orange) flashes	F.G. is not connected	Check whether the F.G. terminal is connected.
		Excessive discharge to nearby metals	Referring to <b>3 INSTALLATION</b> , place the head away from nearby metals. Higher discharge frequency may help reduce excessive discharge.
Error OFF	ERROR indicator (red) flashes	Communication error between head and controller	Turn on the power again. If this error occurs as a result of power shutoff during setup, press the SET UP button again to complete setup.
		Abnormal discharge to nearby metals.	Check whether the head is installed in appropriate environment. Also, check whether any metal may come close to the discharge needle.
		Abnormal discharge from the charge removing object.	A large amount of static buildup on the charge removing object may cause abnormal discharge. Increase the installation distance and the speed of charge removal with air.
		Foreign objects attached to the discharge needle.	Foreign objects may cause abnormal discharge. Clean the discharge needle and its surroundings before use.
		Dew condensation around the discharge needle.	If the temperature environment changes rapidly, abnormal discharge may result due to dew condensation. Clean the discharge needle and its surroundings, and use it under a stable environment.
		Air is dirty.	Water or oil content in the air attached to the discharge needle may cause abnormal discharge. When air is used, use clean dry air only.
		Head not connected.	Check whether the head is connected to the controller.
-	Level meters (green) flash	Setup is not completed.	Press the SET UP button to lock in the setting.
-	Level meters (green) light up in order	Performing setup	It takes 30 seconds to 1 minute to complete the setup.
-	Level meters (green) flashes	Initializing mode	Check that the position of the ion balance setting switch is in Initializing setting mode. Refer to <b>3 SETTING</b> for details.
-	All indicator flash momentarily	Output short circuit.	Check whether the output is shorted or whether the output load is too high.

- In case you got electric shock except discharge needle, F.G. terminal of controller is not connected properly. Be sure that the F.G. terminal is connected properly at the end.

## 9 MAINTENANCE

- Be sure to turn off the power and air before performing maintenance work.
- Since the tip of the discharge needle is pointed, take sufficient care when cleaning.

- Clean the discharge needle and its surroundings, where dirt or dust accumulates after long use.
- Clean it regularly, about once a week. Otherwise optimum charge removal performance may not be achieved, and accidents or operating problems may occur.
- The discharge needle is a consumable part. If charge removal performance does not return to normal after the discharge needle has been cleaned, then the needle unit should be replaced.
- When replacing the discharge needle unit because of natural wear and use, replace all units at the same time.

### How to clean the discharge part

1. Always make sure that the discharge control switch or the power is OFF.
2. Remove any dirt from the discharge needle and its surroundings using a brush, cotton swab, etc. moistened with alcohol.

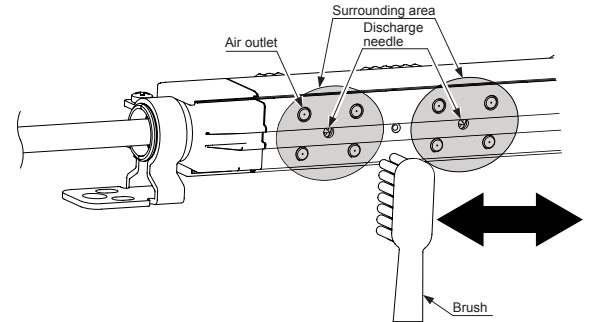

- In case of supplying air, there is possibility that around discharge needle or entire discharge unit get dirty by oil or moisture included in the supplying air. Before replacing the discharge unit, check the blot around discharge needle and clean the entire unit and check the dischargeability is recovered. (the discharge needle unit can be cleaned up easily with commercial super sonic washer.)

### How to replace discharge needle unit ER-XANT

1. Slide the lock release lever of the discharge needle unit in the arrow 1 direction shown in the illustration below.
2. Pull out the discharge needle unit toward the arrow 2 direction.

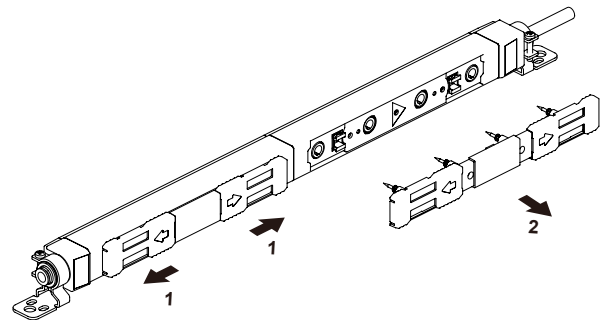

3. Insert the discharge needle unit ER-XANT (sold separately) in the arrow direction.
4. Slide the lock release lever of the discharge needle unit in the arrow 4 direction to lock in the discharge needle unit.

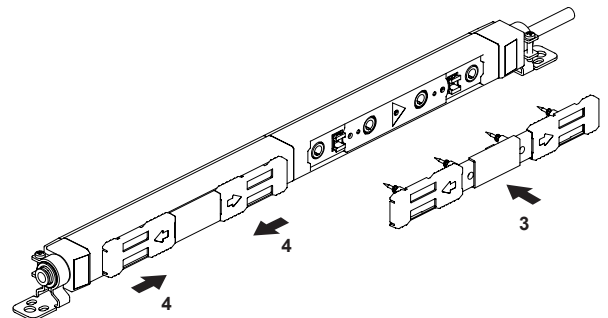

- Notes:
- 1) Do not touch the interior of the main body when the discharge needle unit is removed. Doing so will cause accidents or operating problems.
  - 2) An O-ring is used at the base of the discharge needle. When replacing the discharge needle unit, make sure that the O-ring is in place.

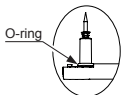

## 10 SPECIFICATIONS

Type	Head			
	Model No.	ER-X016	ER-X032	ER-X048
Effective charge removal width	160mm	320mm	480mm	640mm
Charge removal time	1 second or less(Note 1)			
Ion balance	±30V or less(Note 1)(Note 2)			
Discharge method	Pulse AC method			
Discharge output voltage	Approx. 7,000V			
Ozone generation	0.01ppm or less			
Maximum air pressure	0.5MPa			
Applicable fluid	Air (dried clean air)(Note 3)			
Ambient temperature	0 to +50°C (with no dew condensation). For storage: -10 to +65°C			
Ambient humidity	35 to 65%RH. For storage: 35 to 85%RH			
Vibration resistance	10 to 55Hz frequency, 0.75mm amplitude for 2 hours in each of XYZ directions (when the power is off)			
Shock resistance	Resistance 100 m/s <sup>2</sup> (approx. 10G), 3 times in each of XYZ directions (when the power is off)			
Enclosure grounding method	Floating			
Material	Main unit enclosure: PPS, Stainless steel (SUS). Head mounting bracket: Stainless steel (SUS). Discharge needle: Tungsten.			
Weight	Approx. 410g	Approx. 530g	Approx. 650g	Approx. 780g

- Notes : 1) In condition of discharge distance 100mm, center of the product, discharge wavelength 50Hz and no air supply.  
 2) Ion balance is average of plus and minus. Also, the specification value is typical value in condition of less than ±10°C ambient temperature change, set the ion balance after 30 minutes of the discharge starting, switching on the ion balance control function.  
 3) The dried clean air is dried (dew point: equivalent of -20°C) and filtered (mesh-size: equivalent of 0.01µm) air.

Type	Controller
Model No.	ER-XC02
Number of charge removal heads connected	Maximum 2 units
Supply voltage	24V DC±10%
Current consumption	450mA or less when connecting 1 heads. 800mA or less when connecting 2 heads.
Indicator	Displays status of Head 1 and 2
DSC (Discharge)	Green LED [Lights up during discharge.]
CHECK	Orange LED [Lights up when dirt, wear, etc. of the discharge needle is detected.]
ERROR	Red LED [Lights up when abnormal discharge is detected.]
Level meter	Green LED [5 levels, Lights up depending on amount of the charge or ion generation.]
Output ALARM ERROR COM (Common)	PhotoMOS relay output <ul style="list-style-type: none"> <li>Maximum load current: 100mA</li> <li>Applied voltage: 30VDC or less (between output-output common)</li> <li>Residual voltage: 1.5V or less (at load current of 100mA)</li> </ul>
Output operation	ALARM: ON when dirt or wear of the discharge needle is detected; OFF when operation is normal. ERROR: OFF when abnormal discharge is detected; ON when operation is normal.
Short-circuit operation	Equipped (automatic reset type)
Discharge control input (DSC OFF)	Discharge allowed: Open. Discharge halt: 24V or 0V shorted.
Ambient temperature	0 to +50°C (with no dew condensation). For storage: -10 to +65°C
Ambient humidity	35 to 65%RH. For storage: 35 to 85%RH
Voltage resistance	AC 1000V, 1 minute, completely charged part/between enclosures
Insulation resistance	20 MΩ or more at DC 250V, completely charged part/between enclosures
Vibration resistance	10 to 150 Hz frequency, 0.75mm amplitude for 2 hours in each of XYZ directions (when power is off)
Shock resistance	Resistance 100 m/s <sup>2</sup> (approx. 10G), 3 times in each of XYZ directions (when the power is off)
Enclosure grounding method	Floating
Material	Enclosure: ABS
Weight	Approx. 130g
Accessories	Power supply / I/O connector: 1 set (Housing 5557-10R, terminal 5556TL [manufactured by Molex Inc.] Ground wire approx. 3.7m: 1pc.

Type	Head connection cable	
Model No.	ER-XCCJ2H	ER-XCCJ5H
Length	2m	5m
Cable	Cabletyre cable with connectors at both ends	
Weight	Approx. 80g	Approx. 190g

## 11 OPTIONS (sold separately)

- Spare discharge needle unit ER-XANT
- AC adapter ER-XAPS-EX

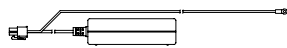

- Power cables ER-XCC2 (2m), ER-XCC5 (5m)



## 12 CE MARKED PRODUCT

- This product is CE marked product.



## 13 RoHS Directive

- This product is in compliance with the RoHS Directive (EU).

## 14 DIMENSIONS (Unit: mm)

- <Head part>
- Head

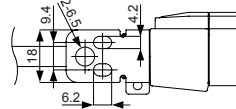
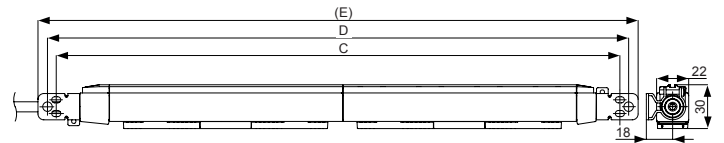
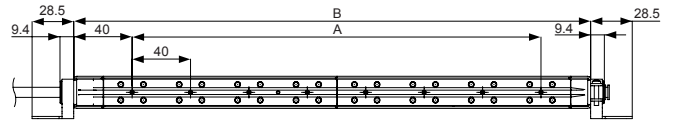

Model No.	ER-X016	ER-X032	ER-X048	ER-X064
A	120	280	440	600
B	194	354	514	674
C	226	386	546	706
D	238	398	558	718
E	251	411	571	731

- High-voltage unit

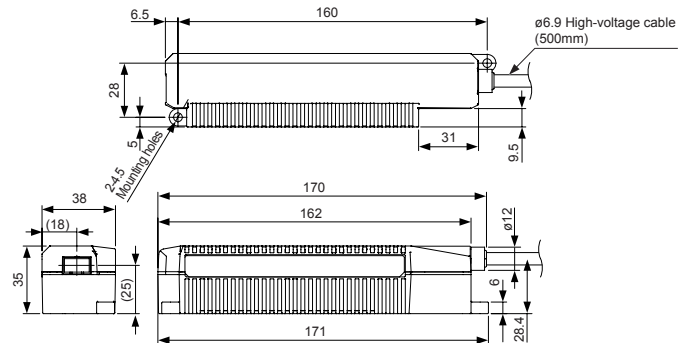

- <Controller>

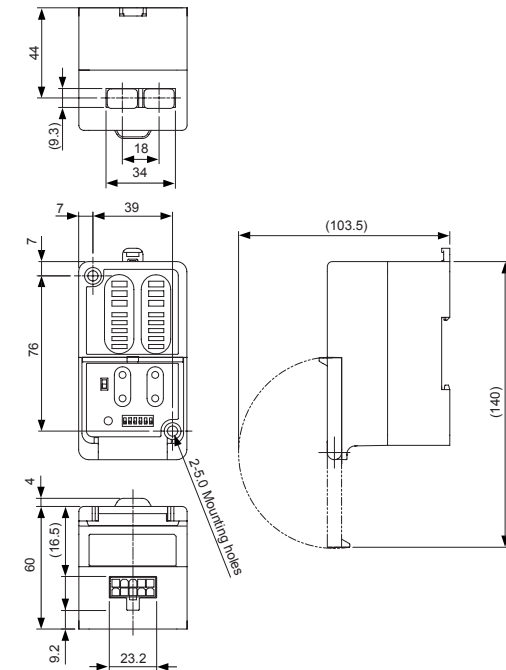

- <Head connection cable>

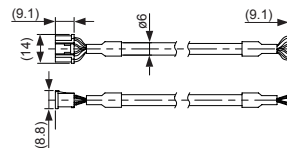

- <Power cable>

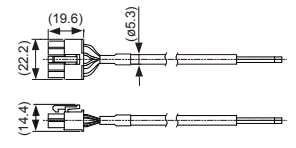

## Panasonic Electric Works SUNX Co., Ltd.

URL : <http://panasonic-electric-works.net/sunx>

### Overseas Sales Division (Head Office)

2431-1 Ushiyama-cho, Kasugai-shi, Aichi, 486-0901, Japan  
 Phone: +81-568-33-7861 FAX: +81-568-33-8591

### Europe Headquarter: Panasonic Electric Works Europe AG

Rudolf-Diesel-Ring 2, D-83607 Holzkirchen, Germany  
 Phone: +49-8024-648-0

### US Headquarter: Panasonic Electric Works Corporation of America

629 Central Avenue New Providence, New Jersey 07974 USA  
 Phone: +1-908-464-3550

PRINTED IN JAPAN

© Panasonic Electric Works SUNX Co., Ltd. 2012