

Profile

- Solid shaft \varnothing 4 mm or \varnothing 6 mm
- Adaptation to various measurement paths owing to a wide range of gear ratios
- Integrated friction clutch to protect the potentiometer
- Compact design
- Potentiometer, power or voltage output
- IP65 protection category

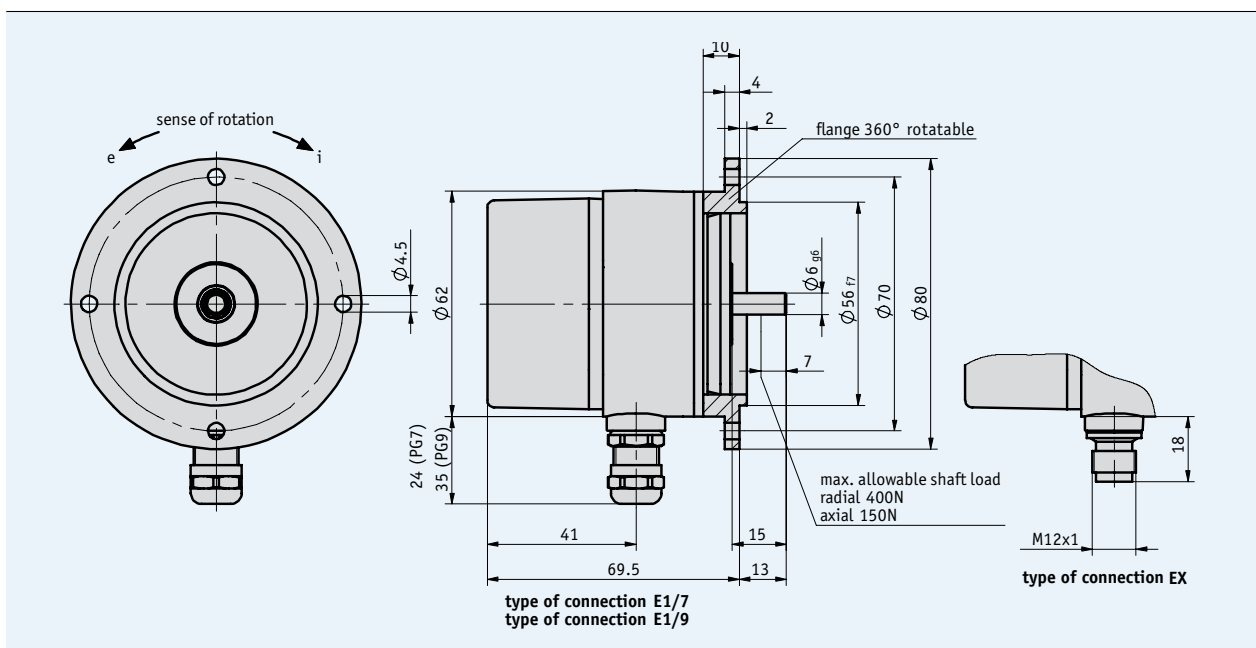

2.3

Mechanical data

Feature	Technical data	Additional information
Gear ratio	0.1 ... 55	
Speed	max. 500 rpm	depending on gear ratio
Operating temperature	-20 ... +80 °C	
Condensation	inadmissible	
Service life of axial movement	1 x 10 ⁶ 2 x 10 ⁶	with P01, P02 with P03
Protection category	IP65	according to DIN VDE 0470
Maximum shaft load	radial 400 N axial 150 N	
Shaft	stainless steel, \varnothing 6 mm	
Housing	reinforced plastic and aluminum	

Electrical data

Feature	Technical data	Additional information
Interference protection class	3	according to IEC 801

Analog outputs

Feature	Technical data	Operating voltage
Potentiometer output	0 ... 1 kΩ, 0 ... 5 kΩ, 0 ... 10 kΩ depending on the potentiometer type used	
Power output	4 ... 20 mA	24 V DC ±20 %, with load ≤500 Ω
Voltage output	0 ... 10 V	24 V DC ±20 %

Potentiometer type

Characteristic/Specification	01	02	03
Design	hybrid	wire	hybrid
Resistance	5 kΩ, 10 kΩ	1 kΩ, 5 kΩ, 10 kΩ	1 kΩ, 5 kΩ, 10 kΩ
Resistance tolerance	±10 %	±5 %	±5 %
Linearity tolerance	±1 %	±0.25 %	±0.25 %
Load rating	1 W at 70 °C	1 W at 70 °C	2 W at 70 °C
Range of rotation	340° ±5° (mechanically straight-through)	3600° ±10°	3600° ±10°
Standard terminal resistor (the higher value is always valid)	0.5 % or 1 Ω	0.5 % or 1 Ω	0.5 % or 1 Ω

Note: Characters highlighted in orange color are order features.

Pin assignment

Potentiometric outputs P01, P05, P10

Signal	E1 (Terminal)	EX (Connector pin)
Po	3	1
Pe	1	2
S	2	3
N.C.		4

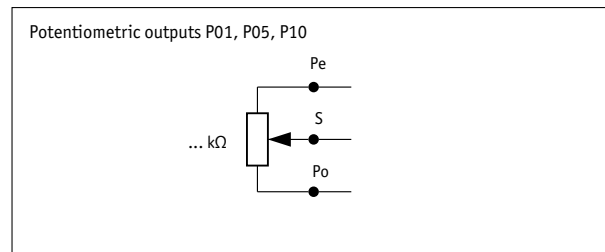

Transducer MWI

Signal	E1 (Terminal)	EX (Connector pin)
I+	1	1
I-	2	2
N.C.	3	3
N.C.		4

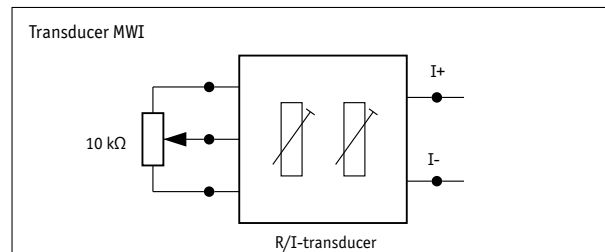

Transducer MWU

Signal	E1 (Terminal)	EX (Connector pin)
+24 V DC	1	1
GND	2	2
U _{out}	3	3
N.C.		4

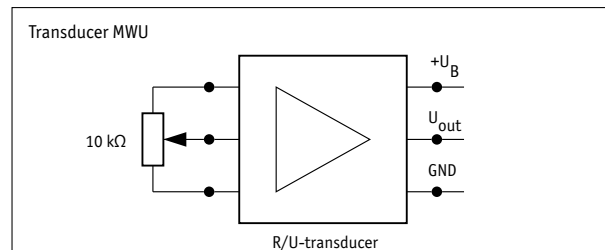

Order

Ratio calculation (order table, feature A)

$$\text{Formula: } i_1 = \frac{n \times 360^\circ}{\alpha}$$

n = number of revolutions on the driving shaft
 α = potentiometer angle of rotation
 340° with 1-coil potentiometer
 3600° with 10-coil potentiometer
 i1 = order feature for gear ratio

If the calculated ratio "i1" is the same as a value in the ordering table for the "ratio" feature, but this is not available, select the next highest ratio.

Order table

Feature	Order data	Specifications	Additional information
Gear ratio	... A	0.1, 0.166, 0.25, 0.333, 0.5, 1, 2, 3, 4, 5, 6, 7, 10, 12, 15, 20, 24, 30, 40, 55 others on request	
Type of connection	E1/7 E1/9 EX B	screwed cable gland PG7 screwed cable gland PG9 for M12 connector	
Potentiometer type	01 02 03 C	1 coil, hybrid 10 coils, wire 10 coils, hybrid	
Analog output	MWI MWU P01 P05 P10 D	transducer 4 ... 20 mA transducer 0 ... 10 V potentiometer 1 kΩ potentiometer 5 kΩ potentiometer 10 kΩ	only with potentiometer type 02 or 03 only with potentiometer type 02 or 03 only with potentiometer type 02 or 03
Sense of rotation	ODR e i E	without indication of sense of rotation counter-clockwise ascending values clockwise ascending values	with P01, P05 or P10 with MWI or MWU with MWI or MWU

Order code

GP03/1 - - V/6 - - - -

A B C D E

Scope of delivery: GP03/1, User information

Accessories:

Mating connectors Page 106
 Self-aligning coupling Page 112
 Electronic display MA50 Page 92

Additional information:

General information and areas of application Page 64 cont.